

1. The monitoring system consisting of the bikeAngel GPS device and the bikeAngel mobile application for smartphones is designed to protect against unauthorized manipulation and theft of the monitored (guarded) device, to detect and inform about a fall or accident, and to precisely locate the guarded device 24/7. This GPS tracker uses both **2G** and **4G** networks.

2. Package content:

BikeAngel GPS device with connecting cables with 4-pin connector, backup battery, quick connectors and velcro.

3. System assembly procedure

3.1 Install the bikeAngel app from Google Play or the App Store (*see point 4. Installing the mobile app*)

3.2 Add a new monitored device in the bikeAngel app (*follow the in-app instructions*)

3.3 Install the bikeAngel device in the guarded car or machine (*see point 5. Assembly of the bikeAngel device*)

3.4 Make sure that you have Bluetooth communication turned on on your mobile. Make sure that the device is in an open area for a few minutes after installation so that it is correctly focused by the satellites. Check the functionality of the bikeAngel device and the app.



Google Play App Store

4. Installing the mobile app and log-in for the first time

After installing the bikeAngel app, register according to the instructions, i.e. enter **Name** (user ID), **E-mail address** (must be real), **Password** (at least a 6-digit alphanumeric string; the system is case sensitive). Finally, confirm your **acceptance of the terms and conditions**.

5. Assembly of the bikeAngel device

5.1 Find on the guarded car the most hidden place for locating the bikeAngel, so that this device is not inside the metal frame and there are as few metal motorcycle components as possible between the device and the sky; The bikeAngel device must be placed with the printed side facing the sky (THIS SIDE UP).

5.2 Disconnect the battery of the guarded car or machine. Attach the bikeAngel device and the back-up battery to the selected location using the included adhesive velcro.

5.3 Bring the wires of the **bikeAngel** to the wiring of the guarded car, which is permanently live, i.e. even when the ignition is off or vehicle is not in motion.

5.4 Connect the **red wire** to the **plus (+) pole** and the **black wire** to the **minus (-) pole** using the included quick clutches. Re-connect the battery of the monitored motorcycle.





5.5 The bikeAngel device starts flashing in the window in the middle of the box, i.e. the connecting to the server is ongoing. After approx. 60 sec. the LED blink turns into double, which confirms the successful data connection with the server. In order to save battery power, the LED stops flashing cca. 15 minutes after the power is connected, and the device continues to indicate its activity only in the app.

6. Turning the guard on and off



You can activate the guard immediately at any time by clicking on "**Turn on guard**" (so-called manual mode indicated by the "key" icon).

Or you can click on "**Turn on automatic mode**", which means that your device will not be guarded when you are near it (within the range of your mobile phone's Bluetooth signal). When you move away from the device, the guard will turn on independently. When you return to the device and make a minimal movement of the device, the guard will automatically deactivate, and you can comfortably leave with it without an alarm. You can monitor the current guard status in the top window of the bikeAngel application.

7. Guarding statuses

-  **Guarding on** - in this state, any movement of the guarded car triggers an alarm
-  **Guarding off** – the guarded car can be used freely, the alarm will not be triggered
-  **Alarm state** - the movement of the car was recorded in the guarded state
-  **Unknown status** - the bikeAngel device has lost connection to the central server. Reasons may be different, such as a disconnected or discharged battery of the guarded car, loss of GSM signal or its low intensity (e.g. in a locality with no or weak GSM coverage or in the underground garages).
-  **Power Saving Mode** - the device was switched to the "stand-by" regime and went into a mode with minimal energy consumption (for long-term or off-season parking).

8. Types of alarm

-  **Hand on a car** - indicates touch or shock of the car during guarding; The vehicle, however, does not move permanently.
-  **Car in motion** - the car is currently moving during the alarm (*high probability of theft*).
-  **Car accident** - indicates that there was a large mechanical overload of the car during the ride due to a fall or impact.

The alarm status is announced by the mobile with regular push notifications, even acoustically when the bikeAngel app is inactive. By confirming the notification, the acoustic indication goes silent, but the alarm state remains in the application until it is canceled by tapping on the status bar of the device and selecting the item "**Turn off the alarm**" in the context menu.

9. Assistance in the event of a crash/accident of the monitored vehicle

If there is a large mechanical overload of the device while driving due to a fall or impact, this information is displayed on your mobile using a push notification. In the right part of the status bar of the device, the "**Car accident**" icon will also appear. After tapping on the status bar of the device, you can call up the "**Accident Information**" function from the context menu, where you can view the location of the guarded device on the map (the notification will not be canceled).

Note: If you want another person (close to you) to receive a message about the fall and be able to help you or at least call you to be sure if you need help, this person must install the bikeAngel application and add your car to the list of monitored vehicles. After that, he/she becomes a full-fledged user of the bikeAngel system and will also receive all the notifications about each device that he/she has added to the list.

10. Power saving mode

Turn on by pressing the **Power saving mode** button. The device switches to power saving mode, which means it stops communicating with the server and switches to battery saving mode. The guarding functionality is still available. The device is “waked up” by movement, shaking the motorcycle or turning it off directly in the application. It is recommended to turn on this mode during any prolonged period of non-use of the car, especially when the vehicle is parked out off-season.

11. Transport mode

Switching on is done by pressing the **Turn on transport** mode button. It is used to transfer the car when you do not want the route to be recorded in the ride list during the move (e.g. transporting the car on a car train). Car monitoring is still available in this mode. The current location of the device can also be found in the application at any time. Switching on is indicated by the icon: 

12. Control of external devices

Switching on is done by pressing the **Turn on external device** button. It is used to remotely control various external devices (horn, turn signals) or to turn on the seat or handle heating via the bikeAngel mobile application. This output is designed for low power, so it is necessary to install and connect a relay with control contacts. Switching on is indicated by the icon: 

13. Locating devices indoors

This function allows you to locate the device more precisely even in places where the GPS signal is no longer available (e.g. in apartment buildings, underground and shared garages). *Bluetooth* must be turned on on your mobile phone. The approximate location of the device is indicated by both sound and graphic signals. There are 4 levels of distance indication. **Grey** background indicates that device is out of range of your mobile. **Red** background indicates signal acquisition, and **orange** followed by **yellow** background indicates signal strengthening and approaching the device. The **green** background indicates the shortest distance to the device being searched. Approaching the device is also accompanied by an increasing frequency of the sound signal. When searching for the device, try to rotate your mobile phone so that you can pick up a possible signal from any direction. We then recommend moving slowly, stopping every few steps and waiting for the signal to stabilize. If you pick up the signal, step slowly in that direction. If the signal weakens, return to the place where you last measured the signal and repeat the search in a slightly different direction. This feature may be limited in areas with RF interference, a large number of Wi-Fi and microwave devices.

14. Location and ride information

By using the context menu, you can find out more detailed information and statistics about all your trips (including their display on the map), the current or last recorded location of your monitored device, and the best navigation to this location.

15. Information about the charge status of the main and backup batteries

 12,3V This icon shows the voltage of the car's main battery in volts. When power is lost, the device switches to the backup battery.

 71% This icon shows the status of the backup battery in percentage. When its voltage drops below 20%, you will receive a notification in the bikeAngel application.

16. Assembly diagram

Connector K1 - 4-pin white connector for mounting into the car
(power supply, output for switching external device)

Pin No.	Name	Description
1	OUT +	Yellow - External device power supply (permanent + pole)
2	OUT -	White - Switched negative pole of external device
3	GND	Black - Negative pole of the car's main power battery
4	PWR	Red - Positive pole of the car's main power battery

Connector K-BATT (2-pin black connector)

Pin No.	Name	Description
1	BATT PLUS	Red - Positive pole of the backup battery
2	SENS	Yellow – Temperature sensor of the backup battery
3	GND	Black – Negative pole of the backup battery

17. Technical specification

Parameter	Value
Supply voltage	5V – 48V
Current consumption	6mA
Transmission frequency	2,4 GHz
Backup battery	3,7V, 450mAh, lithium-ion

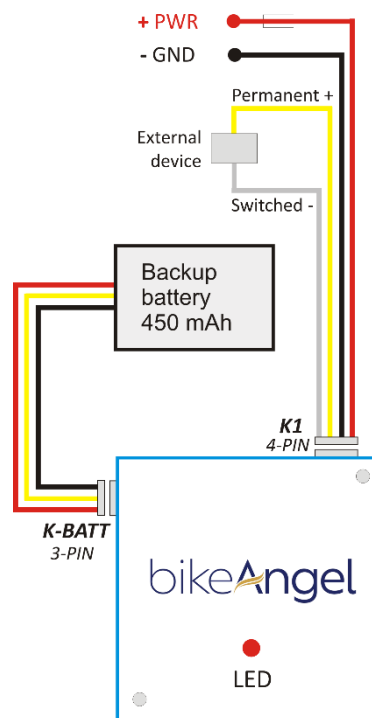

Place for sticker
with serial number (SN/UID)
and device code (CODE)

We wish you many safe kilometres!
Your Team bikeAngel